

Northpoint 26' Greenhouse Assembly Instruction Manual

40 Londonderry Tpk., Hooksett, NH 03106 • Phone: 1-877-746-6544
Email: customerservice@rimol.com • Web Site: <https://www.rimolgreenhouses.com/>



Materials Included

Refer to the separate “pick” list for details on part numbers and quantities.

Additional Tools Recommended

- Cordless drill or impact driver
- 8' step ladders
- Utility knife
- Clamps
- 4' level
- 100' or longer tape measure
- Deep socket set with an adaptor for your drill
- Sledgehammer
- Sharpie markers
- Circular saw with wood blade if wood-framed ends
- Jigsaw or reciprocating saw with metal blade for polycarbonate or steel framing
- Extension cords

RGS provides a care kit with a ground post driver, a 5/16” magnetic driver for TEK screws and wood-mate screws, a line level, a 3/8” drill bit and mason line.

Always refer to your pick lists for parts to be used in each step of the construction process.

READ THROUGH EACH SECTION OF THE MANUAL FIRST BEFORE YOU ENGAGE IN THE ASSEMBLY PROCESS. THIS WILL HELP YOU FULLY UNDERSTAND THE CONSTRUCTION PROCESS.

Contents

PART LIST	3
ILLUSTRATED PARTS LIST.....	4
ILLUSTRATED PARTS LIST- CONTINUED	5
ILLUSTRATED PARTS ASSEMBLY	6
ILLUSTRATED PARTS ASSEMBLY CONTINUED.....	7
STEP1 LAYING OUT YOUR GREENHOUSE AND INSTALLING GROUND POSTS	8
STEP 2 BOW ASSEMBLY WITH TRUSS SUPPORTS & TRUSS BRACES.....	14
STEP 3 INSTALLING THE BOWS INTO THE GROUND POSTS	17
STEP 4 PURLIN INSTALLATION.....	20
STEP 5 INSTALLING WIND BRACING	23
STEP 6 BASEBOARD INSTALLATION	25
STEP 7 FRAMING END WALLS	27
STEP 8 ROUGH OPENINGS FOR EQUIPMENT:	29
Examples of other framing	43
LIMITED WARRANTY	45
LIMITATION OF LIABILITY	45
JURISDICTION.....	45

PART LIST

Description	Part Number
5/16" HEX NUT	FC163104+LH
5/16" X 1 1/2" CARRIAGE BOLT	FC21259+LH
5/16" X 2 1/2" CARRIAGE BOLT	FC21263+LH
5/16" X 4" CARRIAGE BOLT	FC21269+LH
#12 X 1" SELF-DRILLING/SELF-TAPPING TEK SCREW	FC31818+LH
2" 2-HOLE PIPE STRAP	FC44614+LH
#12 X 1 1/2" STAINLESS STEEL WOODMATE SCREW	FC73108+LH
1 3/8" BRACE BAND	HBB138+LH
1 5/8" BRACE BAND	HBB158+LH
1 5/8" X 1 3/8" CROSS CONNECTOR SET (CRO1660)	J4PN0160+LH
1.66 OD 26FT HALF END BOW	RGS26END+LLL
1.66 OD 26FT HALF MIDDLE BOW	RGS26MID+LLL
TRUSS BRACE (26')	RGS26TB+LP
TRUSS SUPPORT W/ PLAIN E FOR 26' GH - 83" LONG	RGS26TSA+LSB
TRUSS SUPPORT W/ SWAGE FOR 26' GH - 86" LONG	RGS26TSB+LSB
WOOD POSITIONING JIG FOR 4' BOW SPACING	RGSAJ+LP
GREENHOUSE CARE PACKAGE W/1.90 GP	RGSCARE190+
STANDARD 3' LONG GROUND POST. 2' IN THE GROUND. 1' OUT OF THE GROUND.	RGSGP3+LP
RIDGE CONNECTOR	RGSRC+LP
RIDGE PURLIN 12'2" HOLES DRILLED EVERY 4'	RGSRP12'2"@4'+LSB
RIDGE PURLIN, SWEDGED 12'3 HOLES DRILLED EVERY 4'	RGSRPSW12'3"@4'+LSB
SIDE PURLIN 12'2" HOLE DRILLED AT END	RGSSP12'2"1H+LSB
SIDE PURLIN, SWEDGED 12'3" (NO HOLES)	RGSSPSW12'3"+LSB
SIDE PURLIN, SWEDGED 12'3" HOLE DRILLED AT END	RGSSPSW12'3"1H+LSB
WIND BRACE FOR 4' BOW SP TRUSS BRACE FOR 34' NOREA (54" LONG)	RGSWB34+LP

ILLUSTRATED PARTS LIST

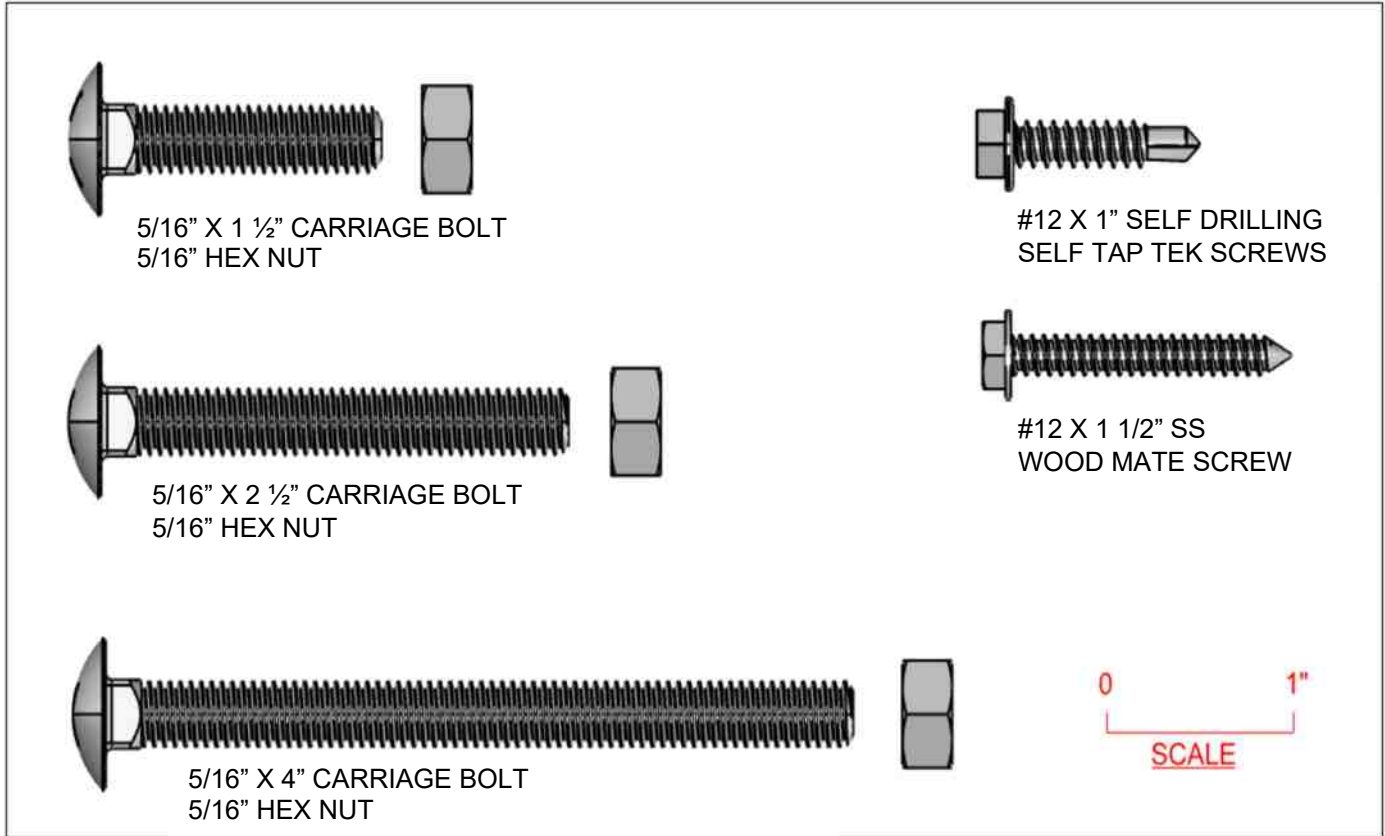

CROSS CONNECTOR



2 HOLE PIPE STRAP



1-5/8" BRACE BAND
1-3/8" BRACE BAND

ILLUSTRATED PARTS LIST- CONTINUED

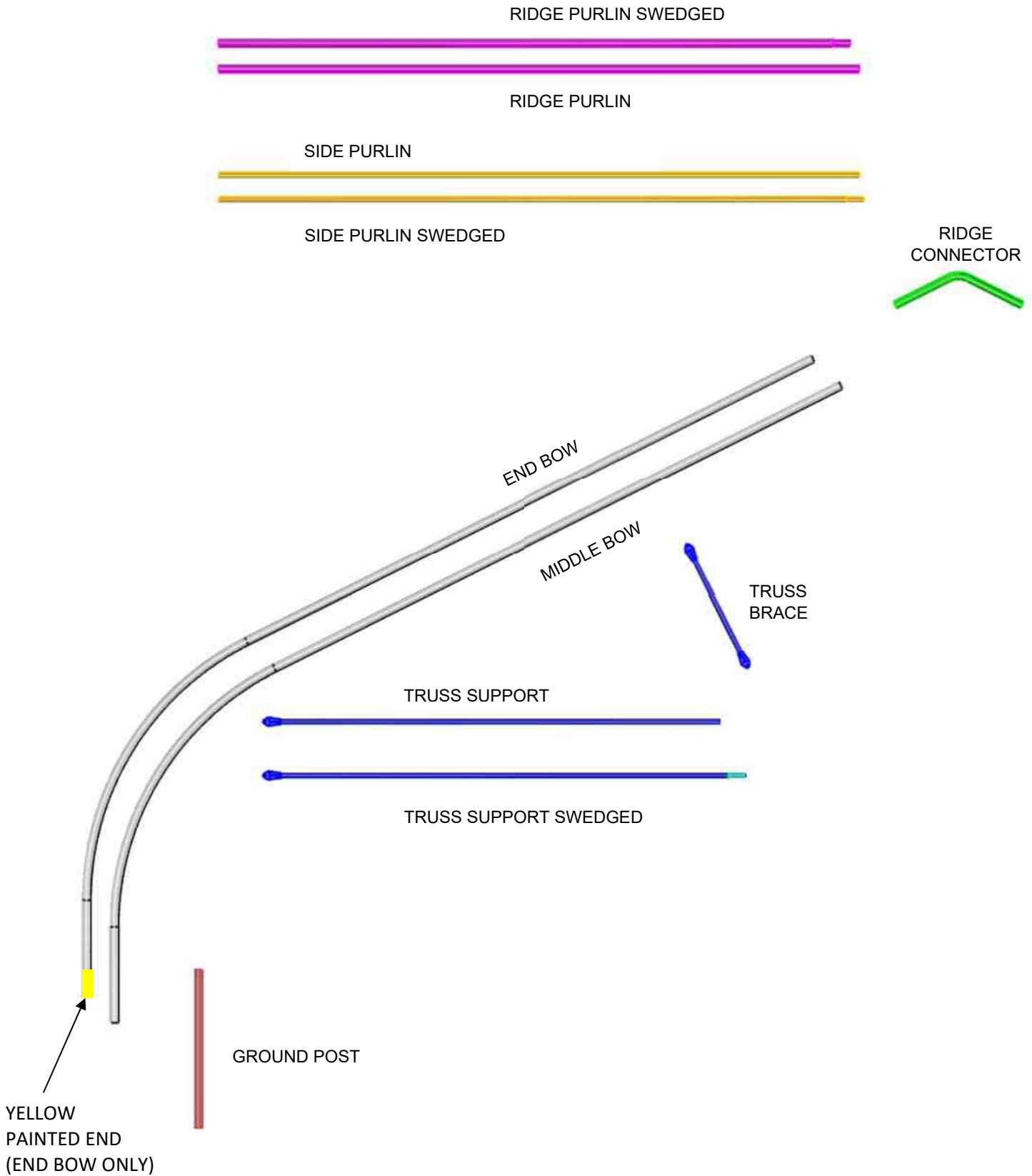

ILLUSTRATED PARTS ASSEMBLY

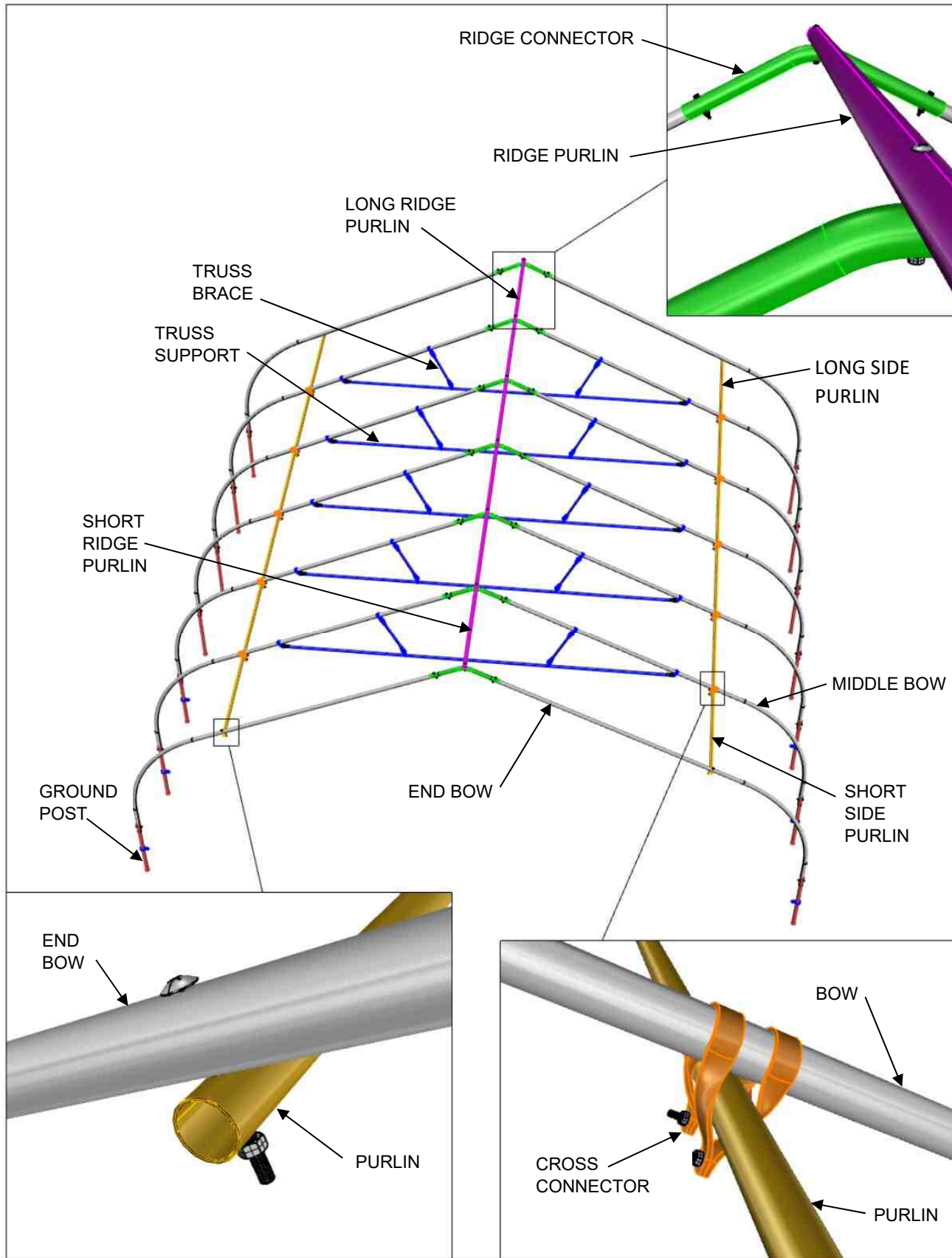

ILLUSTRATED PARTS ASSEMBLY CONTINUED

BOW ASSEMBLY

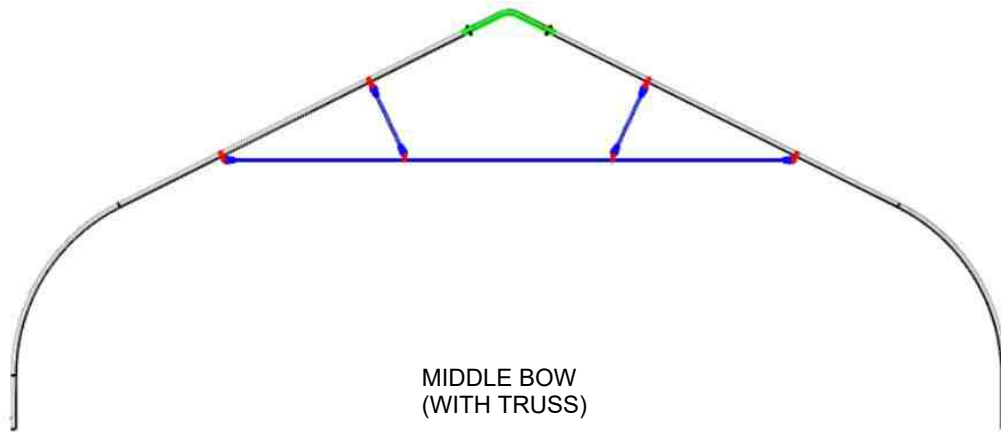
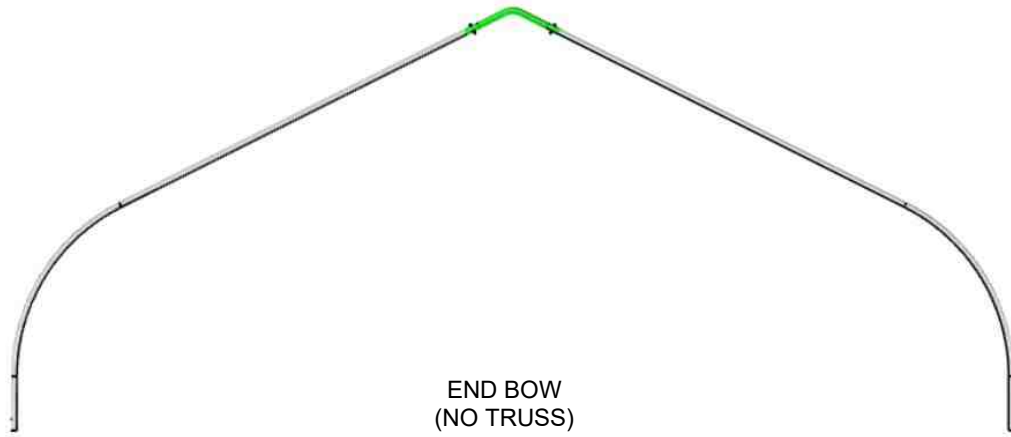

ASSEMBLY INSTRUCTIONS

STEP1 LAYING OUT YOUR GREENHOUSE AND INSTALLING GROUND POSTS

Parts Needed for STEP 1

Ground Post 3' Standard or Optional Ground Post
RGS CARE KIT CONTAINS:

- *Mason Twine*
- *Line Level*
- *Ground Post Driver*
- *5/16" Magnetic Driver*
- *3/8" Drill Bit*
- *Roll 2" Poly Repair Tape*

STEP 1.0 Make sure your site location is as clean and level as possible. A level greenhouse is especially important from end to end, and the site must not have more than a few inches of height difference. If you have rocky or very hard soil, you should consider either renting a power auger or digging a continuous trench and backfilling it with clean soil.

RGS CARE KIT (*mason twine, 5/16" magnetic driver for screws, line level and the ground post driver*)



1.1 Layout your ground posts. Refer to your pick list and determine how much of your ground post will be in the ground and out of the ground (See Figure 1.2). The bolt holes are at the top of the ground post. Make sure your ground post is plumb, and the holes at the top of the ground post are facing inside and outside of the greenhouse.

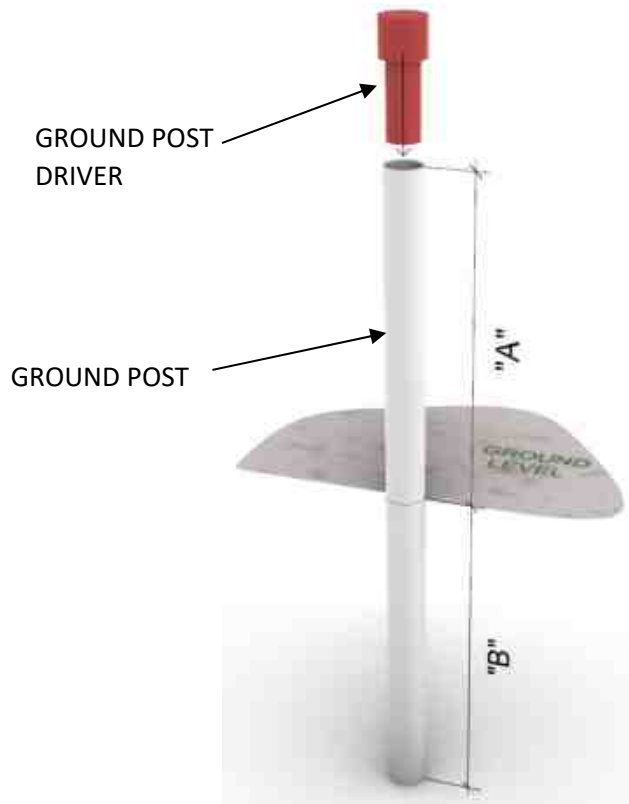

FIGURE 1.2

GROUND POST (LENGTH)	ABOVE GROUND DIM A	BELOW GROUND DIM B	RGS PART#
3'	12"	24"	RGSGP3
4'	24"	24"	RGSGP4
5'	30"	30"	RGSGP5
6'	36"	36"	RGSGP6
7'	48"	36"	RGSGP7
9'	60"	48"	RGSGP9

- 1.2 Determine a corner of the greenhouse, and using the ground post driver and a sledgehammer, bang the ground post into the ground.
- 1.3 Install the next corner ground post the length of your greenhouse. The most common lengths are typically 48', 72', 96' or 144', but your greenhouse may be a different length. The dimensions of the greenhouse are "on center" dimensions, so you are measuring from the center of each post to get your lengthwise measurement.
- 1.4 To get the 3rd corner ground post correct, you will need to use 2 tape measures to check the measurements of the opposite corner and the ground post across the width.
- 1.5 To get the last corner post correct you will also use 2 tape measures to figure the length and the width.
- 1.6 Check the diagonal measurements of each of the opposite corners. They should be within 1" of each other. Equal-length diagonal lengths will ensure the greenhouse is square. The diagonal measurements are as follows for each length greenhouse.

$$26' \text{ width } 48' = 54' 7''$$

$$26' \text{ width } 72' = 76' 6''$$

$$26' \text{ width } 96' = 99' 6''$$

$$26' \text{ width } 144' = 146' 4''$$

Tip: The way to determine the diagonal measurement is to use formula $C^2 = A^2 + B^2$

$(A \times A) + (B \times B) = (C \times C)$.

A is the width of the greenhouse, B is the length of the greenhouse and C is the diagonal of the greenhouse. For example, $(26 \times 26 = 676) + (48 \times 48 = 2,304) = (2,980$, then take the square root of this which is 54'- 7" ft.)

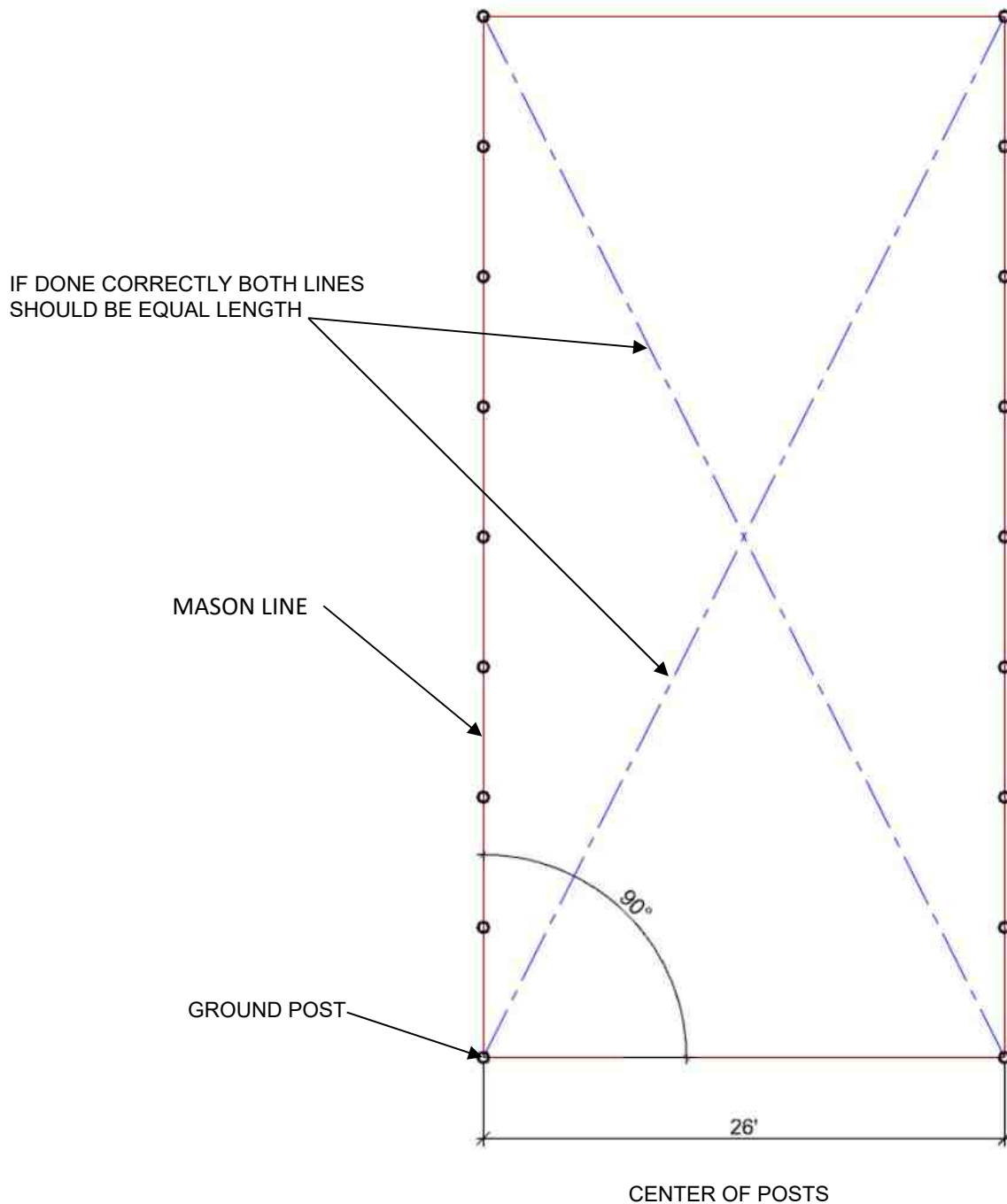

1.7 After the four corners are set and the ground posts are level and plumb, you are now ready to install the remaining ground posts. The ground posts are commonly located 4' on center but post spacing may be different if you purchased a greenhouse with either 2', 3' or 6' bow spacing. Using your 100' tape measure, mark the locations of each ground post on the string lines.

1.8 Using the twine and a line level, run a string line from one ground post to the other ground post to. Run the string line around the holes at the top of the ground post. Pull the twine tight to get an accurate reading. We provide a line level for you to make sure your string lines are level, however for greenhouses 96' or longer, we recommend using a laser level or a transit.



Tip: Alternatives to using the ground post driver include the following: You can purchase a metal fence post driver from a hardware store or fence company (These are useful when driving in taller ground posts that are 6 ft. or higher and cost around \$40) or you can rent or buy a gas-powered post driver, which is the most efficient way to install ground posts.



If you have plated ground posts, refer to the Figure 1.3 and Figure 1.4 below for attaching the ground posts to concrete.

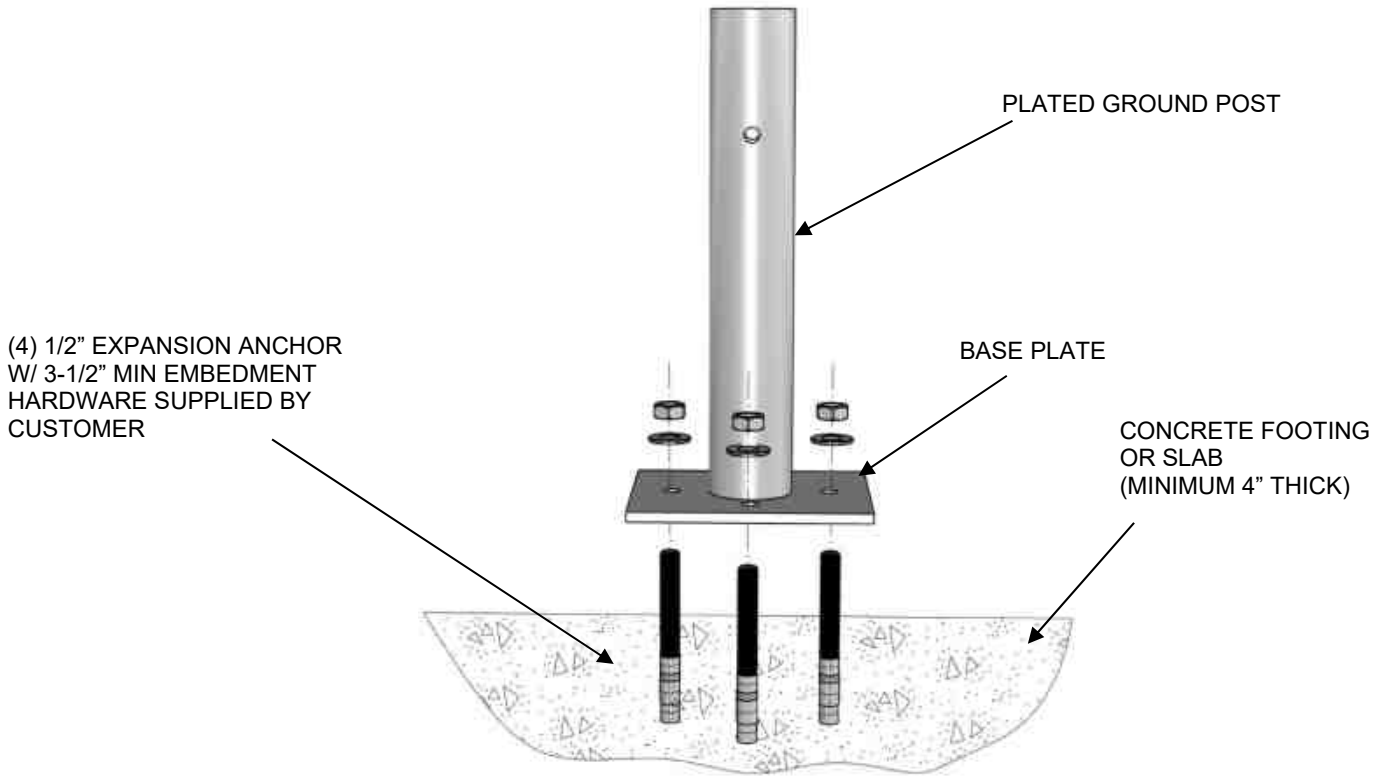

FIGURE 1.3

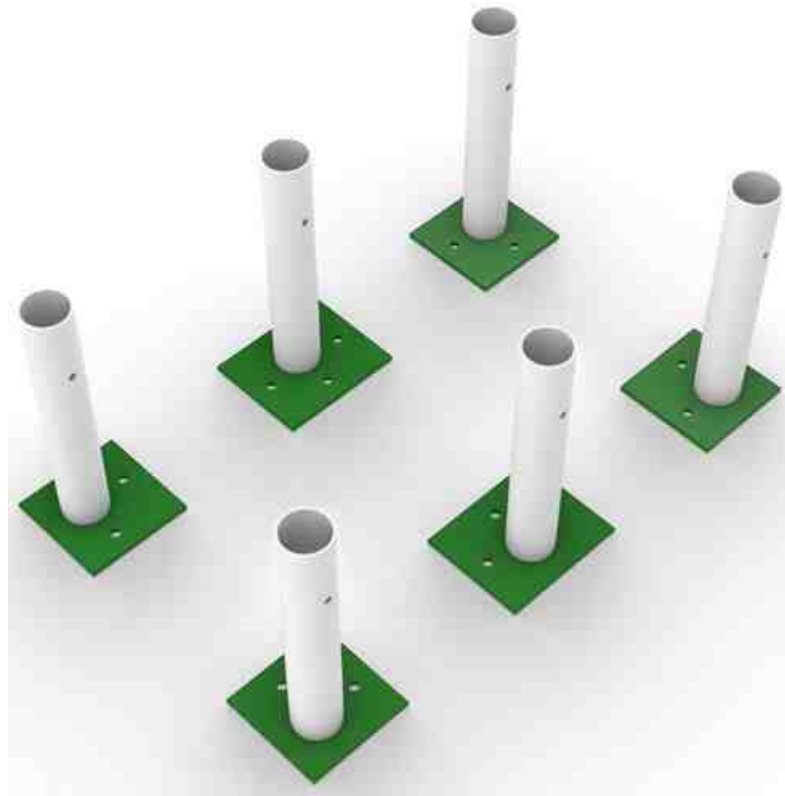

FIGURE 1.4

STEP 2 BOW ASSEMBLY WITH TRUSS SUPPORTS & TRUSS BRACES

Parts Needed for STEP 2

Half End Bows
Half Middle Bows
Ridge Connector
Truss Support
Truss Brace

1 5/8" Brace Band
1-3/8" Brace Band
#12 x 1" TEK Screws
5/16" X 1 1/2" Carriage Bolt and Nuts
5/16" X 2 1/2" Carriage Bolt and Nuts
5/16" Driver (provided)

STEP 2.0 Assemble the half end bows (with painted ends) and half middle bows to the ridge connector. Attach the truss support and truss braces to the bow assembly.

STEP 2.1 Lay out your bows and ridge connector on a flat and clean surface. The bows will insert into the ridge connector. See Figure 2.0

FIGURE 2.0

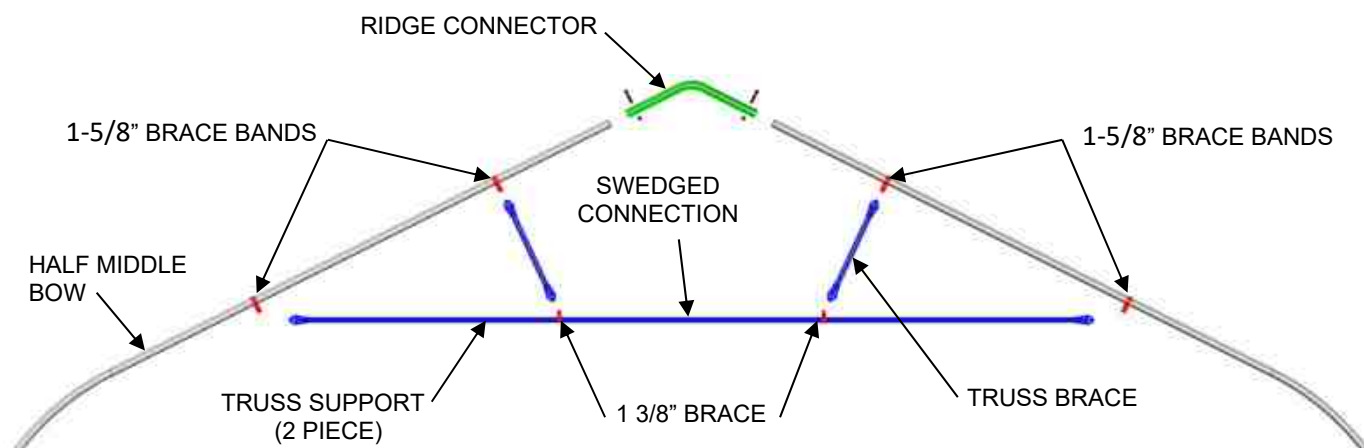

BOW ASSEMBLY (EXPLODED VIEW)

FIGURE 2.1

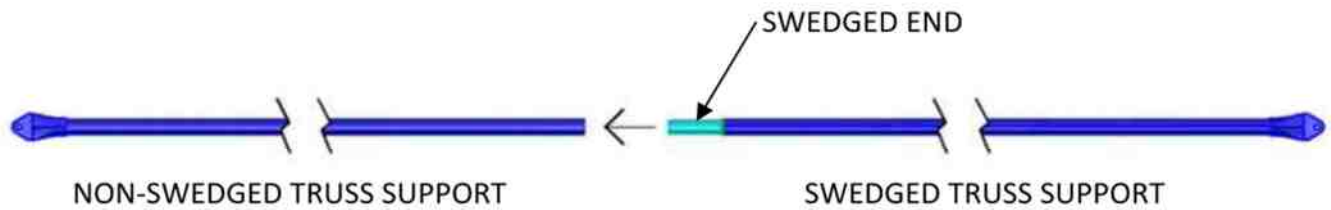

2.2 Attach the truss support and two brace bands to the bow assembly using 5/16" x 1 1/2" carriage bolts and nuts. See Figure 2.2

FIGURE 2.2

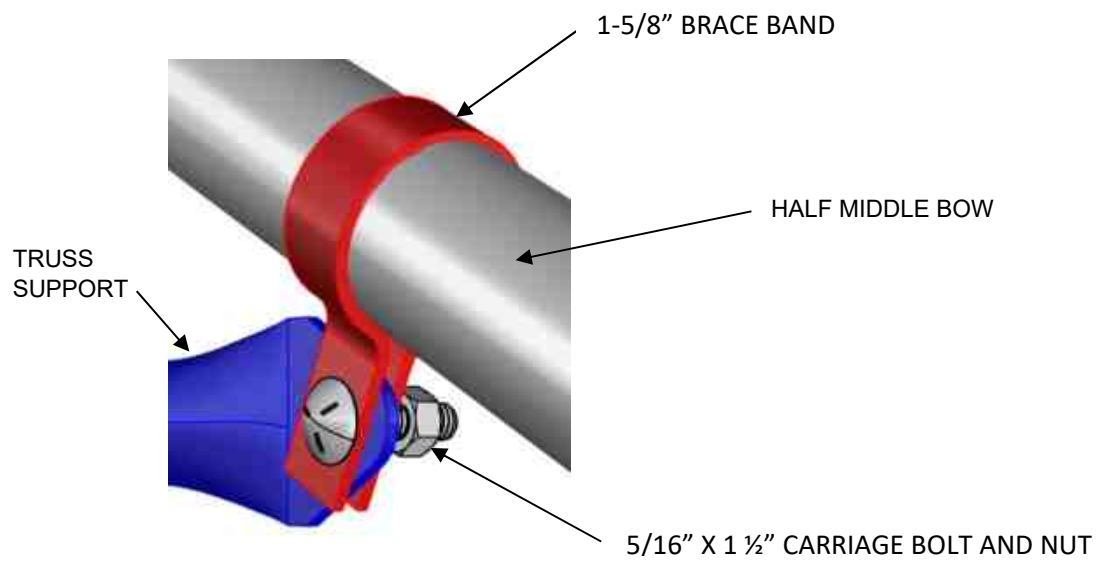

2.3 Slide (2) 1 5/8" brace bands onto each side of the bow assembly. See Figure 2.3

FIGURE 2.3

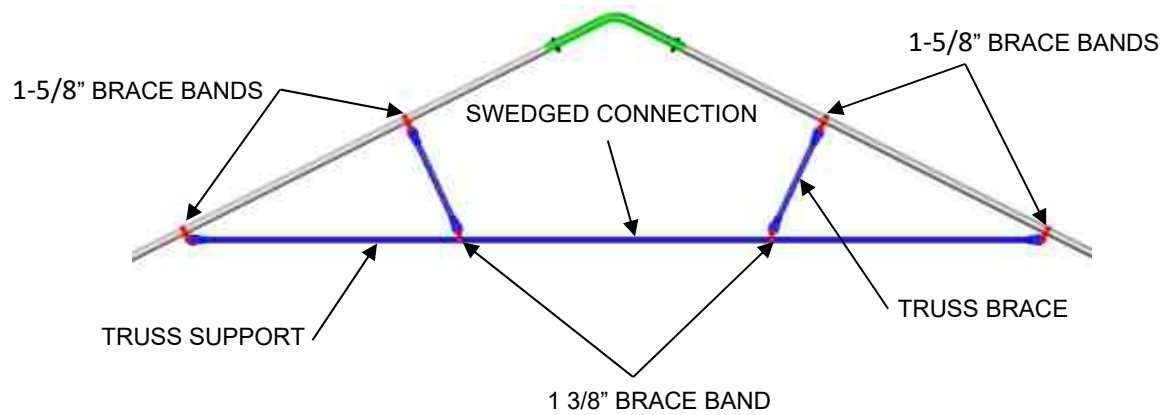

2.4 Prior to connecting the two truss supports together, slide a 1 3/8" brace band onto each tube. See Figure 2.3 Then insert the swedged piece into the non-swedged piece (See Figure 2.1) and fasten with (2) #12 x 1" TEK screws into the connection as shown. Use the 5/16" driver provided. See Figure 2.4

FIGURE 2.4

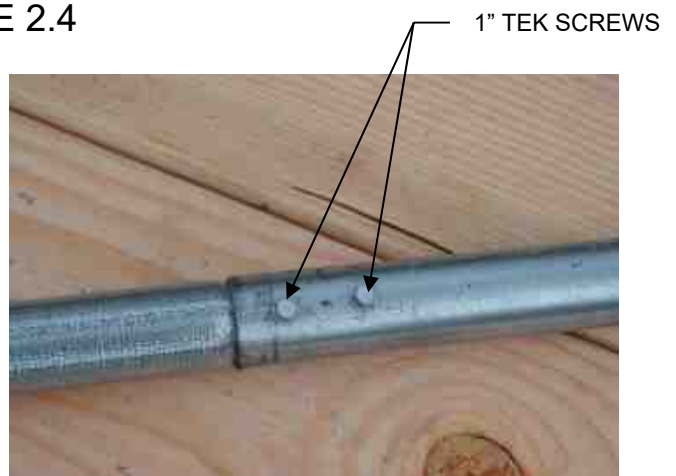

2.6 Attach the assembled truss support to the bow assembly (See Figure 2.0 and Figure 2.2) using the brace band on the bow to connect to the truss support with the 5/16" x 1 1/2" carriage bolt and nut. Align with black marks and tighten.

2.7 Attach the truss braces to the bow and truss support (See Figure 2.3). Align with red marks and tighten.

STEP 3 INSTALLING THE BOWS INTO THE GROUND POSTS

Parts Needed for STEP 3

Bow Assemblies

5/16" X 2 1/2" Carriage Bolts and Nuts

3.1 The first bow assembly that will be installed into the ground posts is the END bow assembly (DOES NOT HAVE A TRUSS) with the painted ends and holes for the purlin connection. END bows will have two holes on each side.

Tip: Prior to installing the bows, slip one 1-5/8" brace band on each side of the first bow assembly, two on each side of the second bow assembly, and one on each side of the third bow assembly at both ends of the greenhouse. The brace bands will be used later when you install the wind bracing.

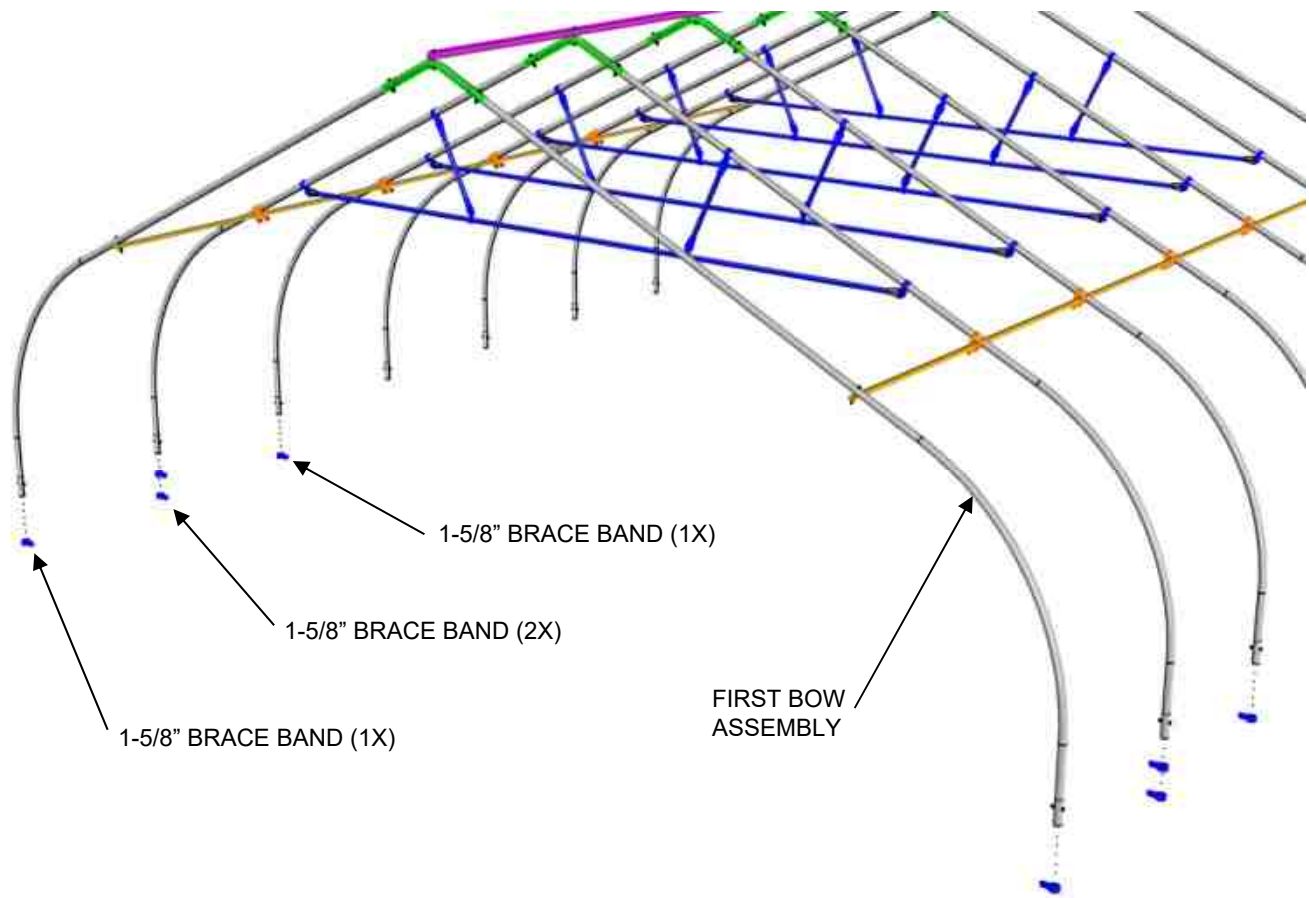

3.2 With two people, lift your bow assembly into the ground posts and attach with the 5/16" X 2 1/2" carriage bolts and nuts.



3.3 Install the remaining middle bow assemblies until you get to the other end of the greenhouse.



If the holes of the ground post and bow do not line up, use a pipe wrench to turn the ground post. If the holes are slightly off with the inserts, you can use a drift pin or a small screwdriver to move the insert to attach the bolt to the assembly.

Impact drivers work well with this process, and you want to make sure that the square part of the carriage bolt is sucked into the ridge connector and ground post.



STEP 4 PURLIN INSTALLATION

Parts Needed For STEP 4

Ridge Purlin

5/16" X 4" Carriage Bolts and Nuts

Side Purlins

Cross Connectors

End Purlin

1/4" X 1 1/2" Carriage Bolts and Nuts

1" TEK Screws

Wooden Jig

4.0 You will begin by installing the ridge purlin. The ridge purlin has holes drilled every four feet (unless you have a special bow spacing for your greenhouse). All the ridge purlins are 12' 3" with a swedged end except for the last purlin. The last purlin does not have a swedged end and is either 12' 2", 8' 2" or 4' 2" depending on the overall length of the structure. Attach using 5/16" x 4" carriage bolts and nuts through each connection. The ridge purlin should be installed on top of the ridge connector. The square shank of the carriage bolt head must be drawn down by tightening nuts so that the head is flush with the ridge purlin.



4.1 Attach the side purlins to the bows. Begin with the uppermost purlins first. The end purlin is 12' 3" long with a hole drilled at the non-swedged end. This will connect to the end bow with a carriage bolt and nut and the purlin should be installed on the underside of the bow. See Figure 4.1

4.2 The remainder of purlins will be installed on the underside of the bows using the cross connectors. The cross connectors use 1/4" x 1 1/2" carriage bolts and nuts. See Figure 4.2 and Figure 4.3 Use the provided wooden jig to help with spacing to make sure the bows remain at a 4' on center measurement.

FIGURE 4.1

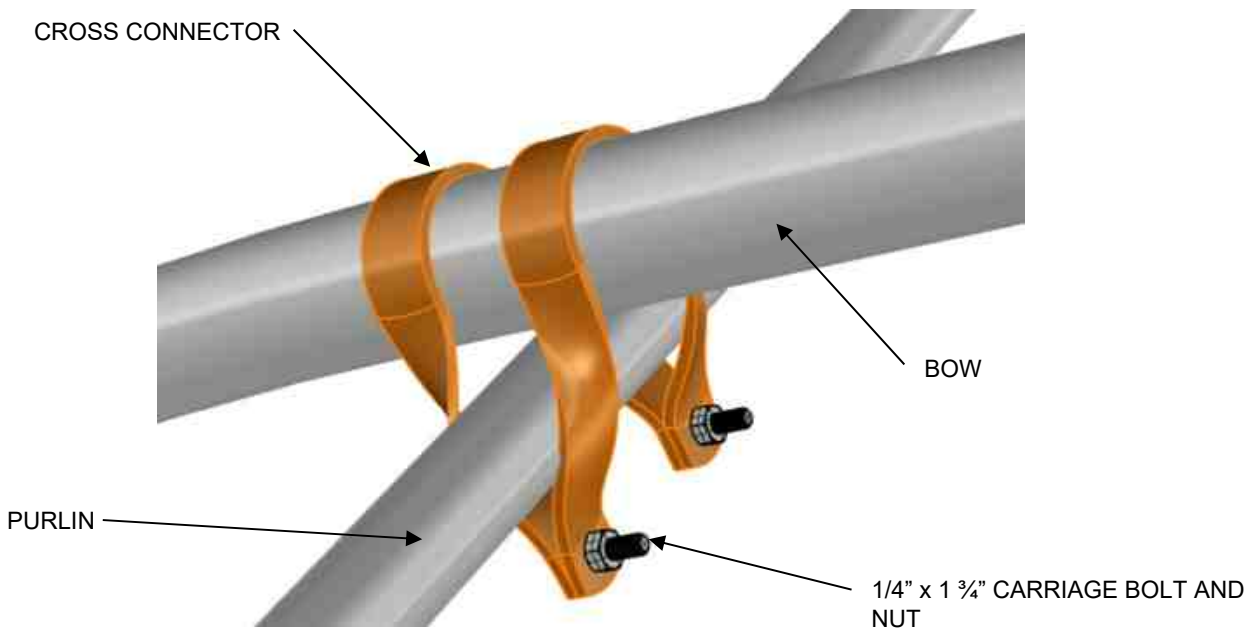
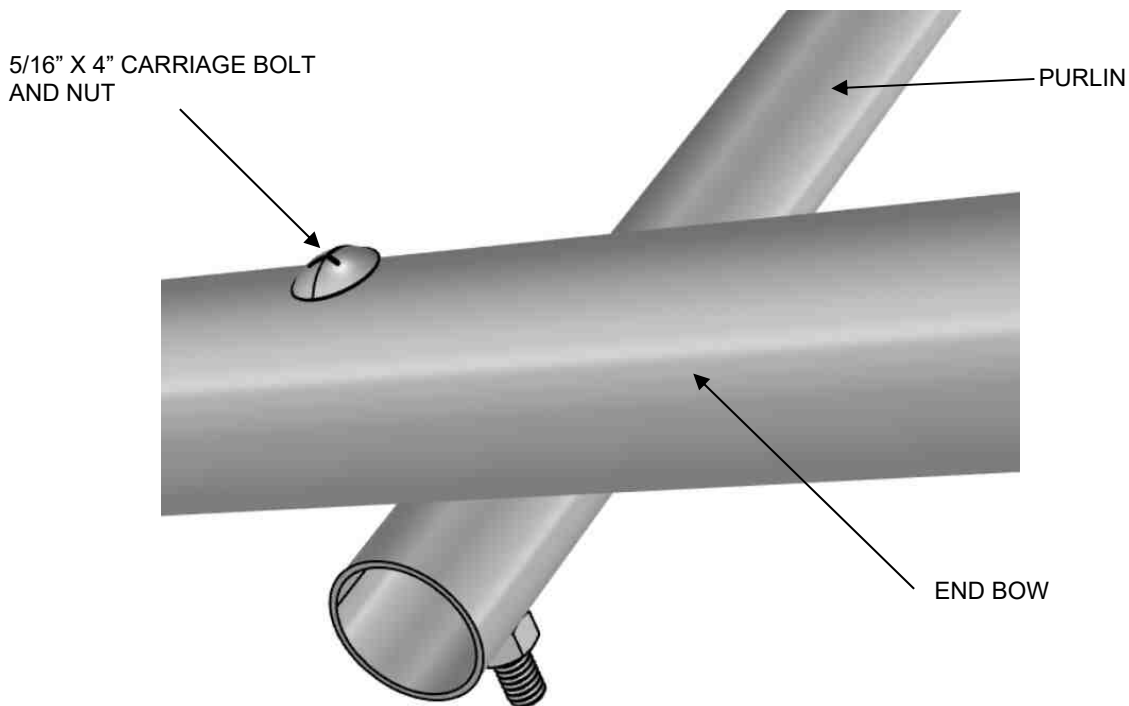

FIGURE 4.2

4.3 At each swedged connection, attach the purlins together using two 1" TEK screws.

FIGURE 4.3



1" TEK SCREWS

STEP 5 INSTALLING WIND BRACING

Parts Needed for STEP 5

Wind Braces

Brace Bands

Bolts And Nuts As Per The Previous Instructions

5.1 Wind braces are 54" long and attach from the end bow to the first bow and from the first bow to the second bow, just above the ground post, in all four corners using brace bands, bolts, and nuts as per the previous instructions. See photo.



Standard wind kit bracing shown.

STEP 5A EXTRA WIND BRACING OPTION

Skip if No

This page shows extra bracing installed with the optional high wind kit. If you have a high wind kit, install the extra wind braces in the upper part of the frame as per the illustration.

Parts Needed for STEP 5A

54" Long Wind Braces

Brace Bands

Bolts And Nuts as Per the Previous Instructions

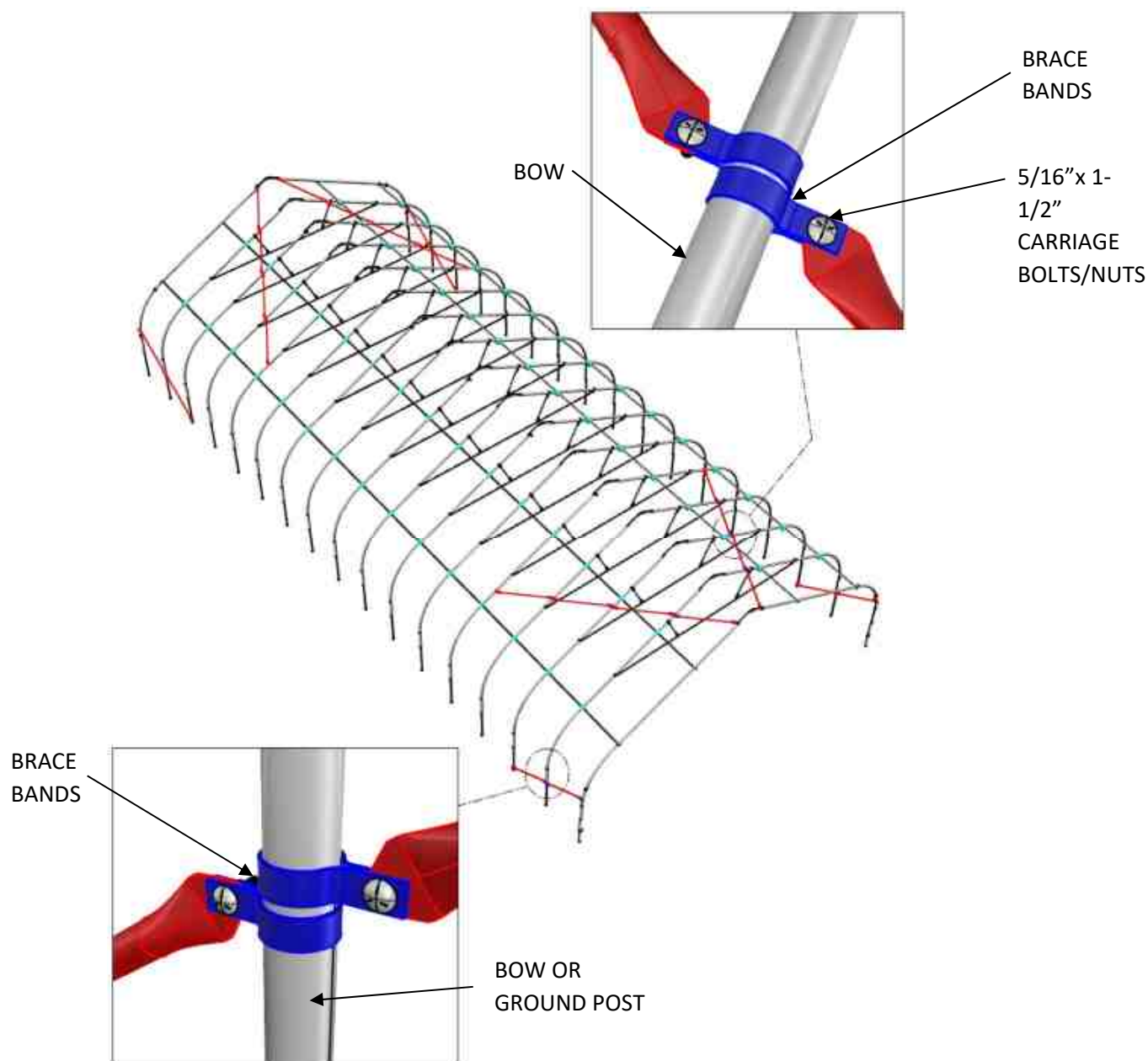

STEP 6 BASEBOARD INSTALLATION

Parts Needed for STEP 6

Large Baseboard
2-Hole Pipe Strap
3/4" Tek Screw
Pipe Strap

Plumb Kit
3/8" Drill Bit Provided
Carriage Bolt

6.1 It is recommended to use as large a baseboard as your budget allows. Either 2 x 10 or 2 x 12 lumber is recommended. Attach your baseboards to the frame at your desired height using two 2-hole pipe straps per ground post connection. Insert 1" TEK screw through each pipe strap to secure it to the frame of the greenhouse. See Figure 6.1

FIGURE 6.1

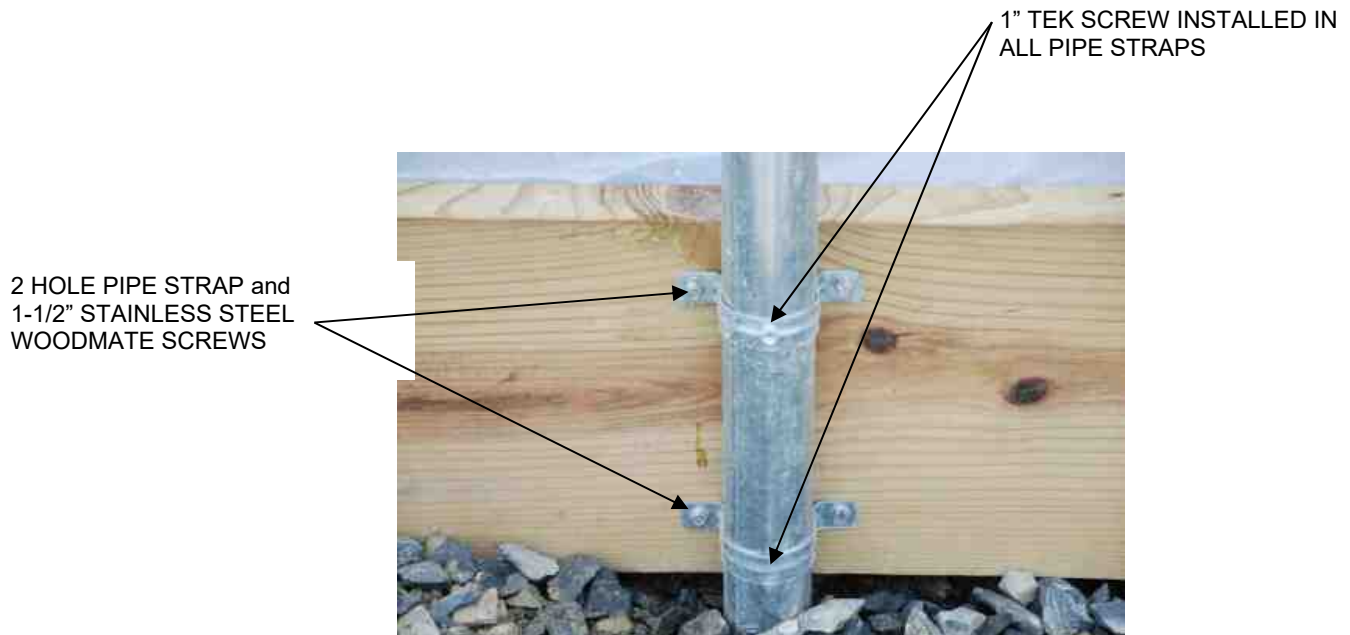

6.2 On the ends of the greenhouse, it is recommended to drill a 3/8" hole using the bit provided through the baseboard and ground post to bolt the baseboard onto the ground post. Use Carriage bolt on ends only. See Figure 6.2

FIGURE 6.2



STEP 7 FRAMING END WALLS

Parts Needed for STEP 7

- *Mason Twine*
- *Plumb Bob*

7.0 First, make sure the greenhouse is plumb. See Figure 7.0

FIGURE 7.0

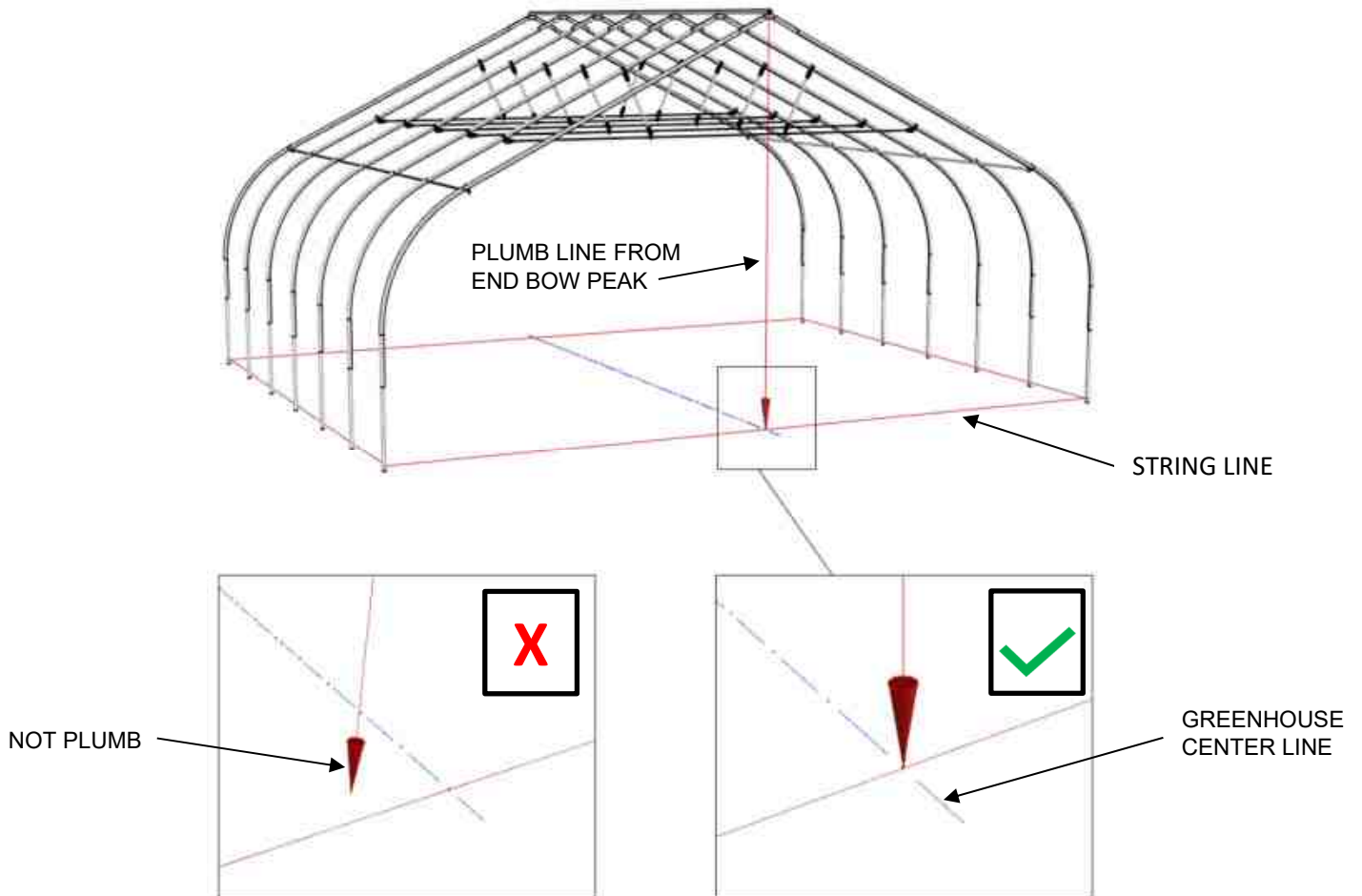

7.1 Pull the greenhouse forward from one end to plumb the greenhouse.

7.2 String a line from one ground post to the other ground post to square.

- 7.3 Read the instructions for your doors and equipment first to double check rough openings and assembly process.
- 7.4 Sketch out where your doors and equipment will be located. See rough openings for all doors and equipment and make note of the dimensions.
- 7.5 See examples of rough openings for doors and equipment. If you need further assistance on the layout, please contact your salesman for more specific information.
- 7.6 You will need six verticals per end wall. Verticals should be set into concrete for stability. One bag of concrete is sufficient as a footing.
- 7.7 Horizontals should have a maximum spacing distance of 4 ft. apart.
- 7.8 See photos of how wood framing and metal framing is constructed.
- 7.9 Read through these entire directions to see illustrations and photos.

Sequence of Construction:

1. First frame out your two center verticals which will most likely be a location of a door.
2. Frame out two verticals on both the right and left side which will be your location of fans, shutters or possibly no equipment.
3. Frame out horizontal members for completion of rough openings for doors and other equipment.
4. Frame out remaining horizontals to fill in gaps where support is necessary for covering end wall of greenhouse.

STEP 8 ROUGH OPENINGS FOR EQUIPMENT:

Tracrite Roll-Up Doors (part # TR940XXX)

Same size as door. Example – an 8' x 8' door has an 8' x 8' rough opening. Note the framing requires a minimum of two pieces of either 2 x 4 lumber or 1 ½" square tubing to support the weight of the door and to properly have enough surface area to attach the door to the frame.

HC Pre-Hung or Sliding Doors (part # HCXXXX)

Double sliding doors-rough opening is 3" less than door width and 1" less than door height.

Example – 4' x 8' double sliding doors have a 93" wide opening and a 95" high opening.

Double hung doors-rough opening is 1 ½" more than door height and 1 ¾" more than door width.

Example – 3' x 7' double hung doors have a 85 ½" high opening and a 73 ¾" wide opening

Single sliding door-rough opening is 3" less than door width and 1" less than door height.

Example – 4' x 8' single sliding doors have a 45" wide opening and a 95" high opening.

Single hung door-rough opening is 1 ½" more than door height and 1 ¼" more than door width. Example-3' x 7' single hung door has 85 ½" high opening and a 37 ¼" wide opening. If you are using steel framing and covering with poly on the ends, double up on the steel framing around the door so that you have a surface to attach the wire lock.

Coolair Fans (part # ACNBFXXX)

NBF24 33 ½" h x 33" w

NBF30 39 ½" h x 39" w

NBF36 45 ½" h x 45" w

NBF42 51 ½" h x 51" w

NBF48 57 ½" h x 57" w

Coolair Shutters (part # ACLRWXXX)

Add ½" on to width and height of shutter. Example-39" shutter is 39 ½" x 39 ½".

Quietaire Fans (part # QTAGCSXXX)

AGCS24 29 ½" h x 28 ¾" w

AGCS30 35 5/8" h x 34 ¾" w

AGCS36 42" h x 40 ¾" w

AGCS42 48 ¼" h x 46 ¾" w

AGCS48 54 ¼" h x 52 ¾" w

Quietiare Shutters (part # QTHDEXXX)

Same as Coolair shutters. See above.

J & D Fans (part # JDVNSXXXX)

VNS24 32" h x 31 ½" w

VNS30 38" h x 37 ½" w

VNS36 42" h x 41 ½" w

VNS48 56 ½" h x 55 ½" w

J & D Shutters (part # JDVRSGXXPS)

Same as Coolair shutters. See above.

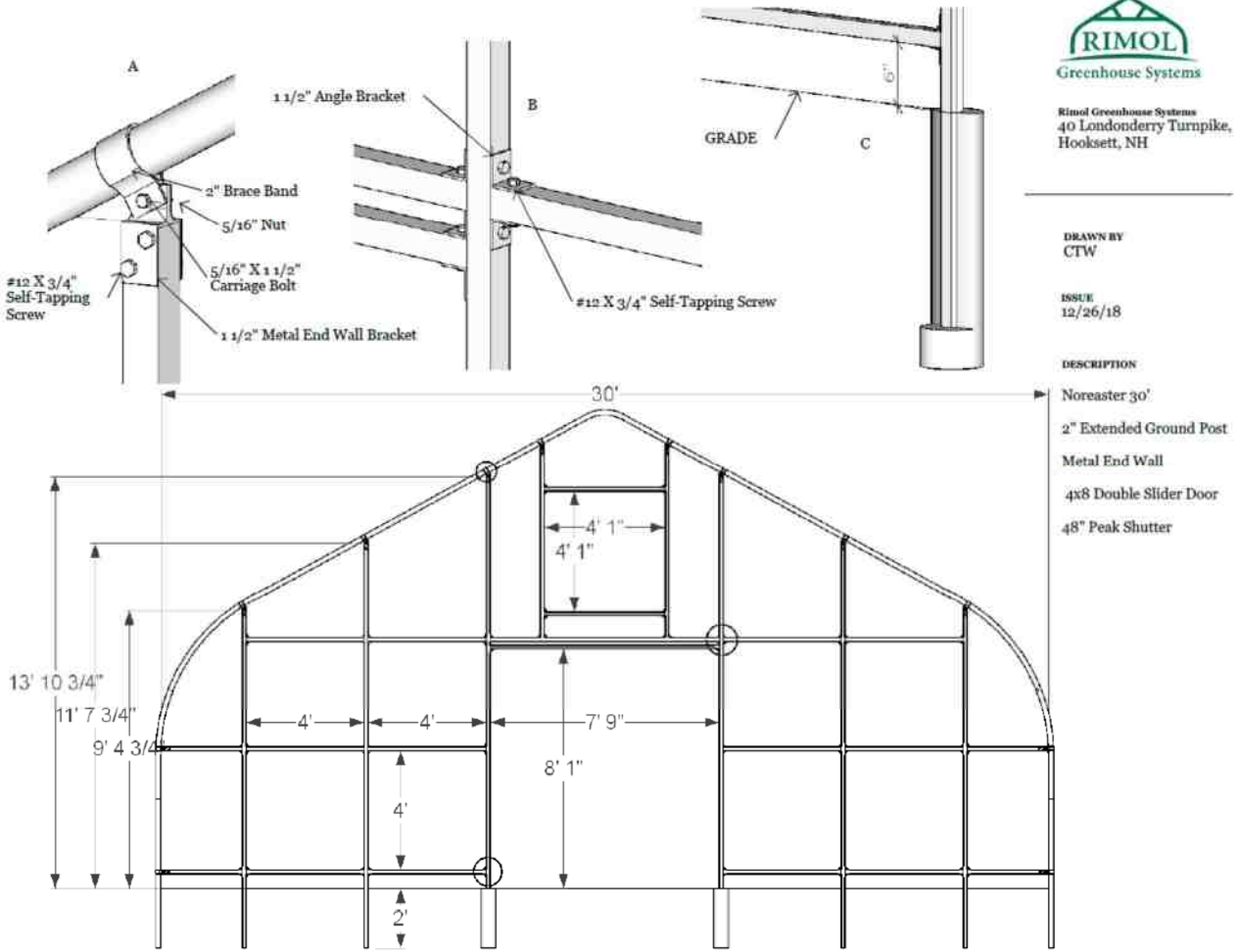

Rimol Greenhouse Systems
40 Londonderry Turnpike,
Hooksett, NH

DRAWN BY
CTW

ISSUE
12/26/18

DESCRIPTION

- Noreaster 30'
- 2" Extended Ground Post
- Metal End Wall
- 4x8 Double Slider Door
- 48" Peak Shutter

Example of an 4 x 8 double sliding door, 48" gable shutter and steel framing on a high tunnel



Rimol Greenhouse Systems
40 Londonderry Turnpike,
Hooksett, NH

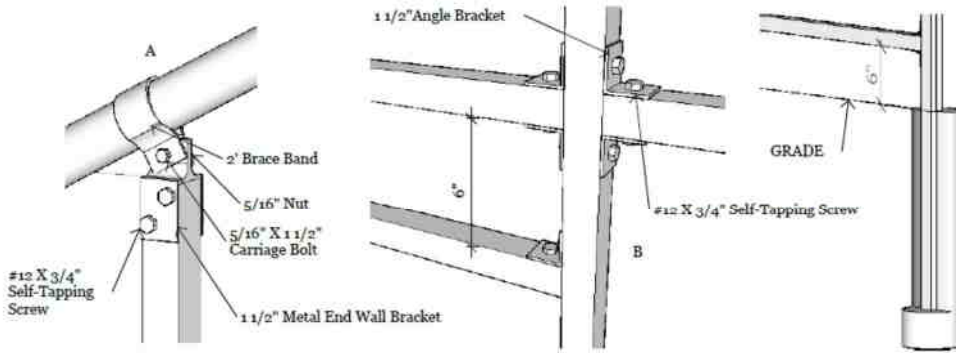

DRAWN BY
CTW

ISSUE
12/26/18

DESCRIPTION
Noreaster 30'
2' Extended Ground Post
Metal End Wall
8x8 Roll Up Door
3X7 Single Hinge Door
48" Peak Shutter

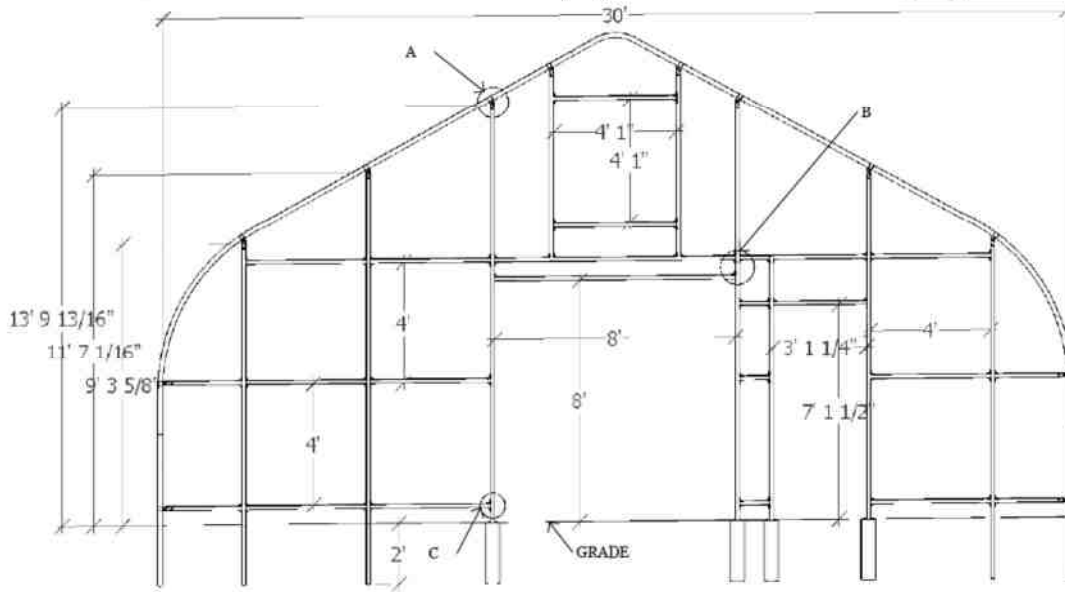

Example of an 8 x 8 roll-up door, 3 x 7 hinged door, 48" gable shutter and steel framing on a high tunnel

2X4 END WALL BRACKET ASSEMBLY

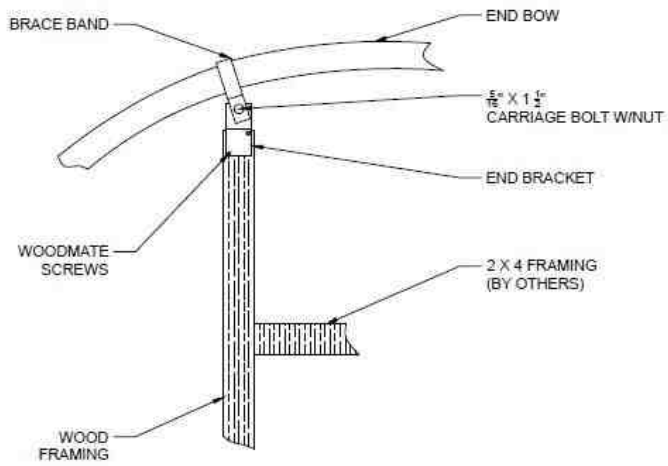

1 FRONT VIEW

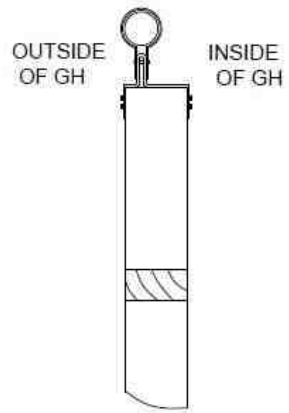

2 SIDE VIEW





This shows how you can use an angle bracket to also connect framing lumber to the bows

METAL END WALL BRACKET ASSEMBLY

ILLUSTRATION 2

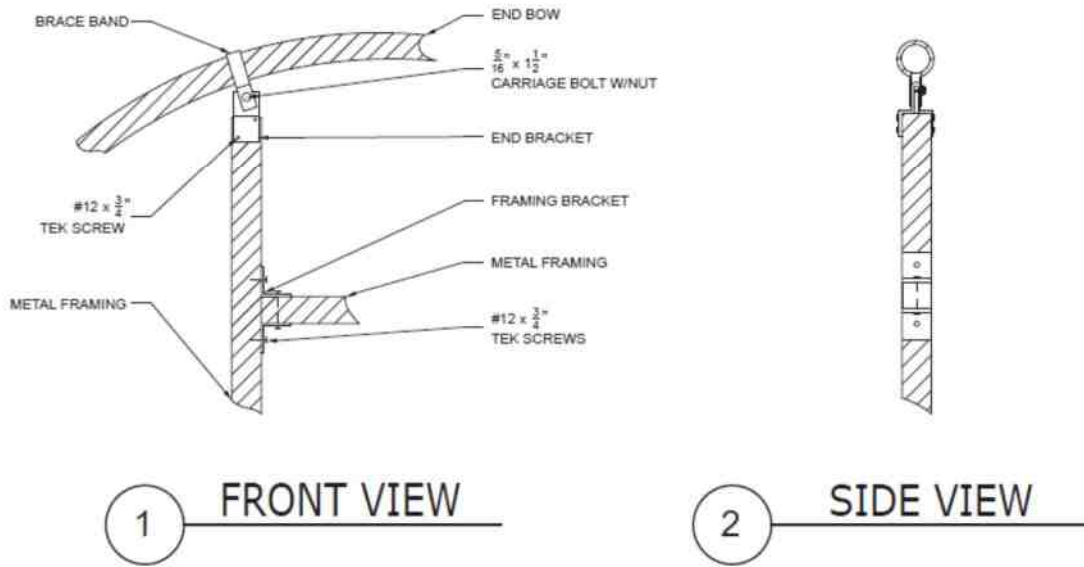

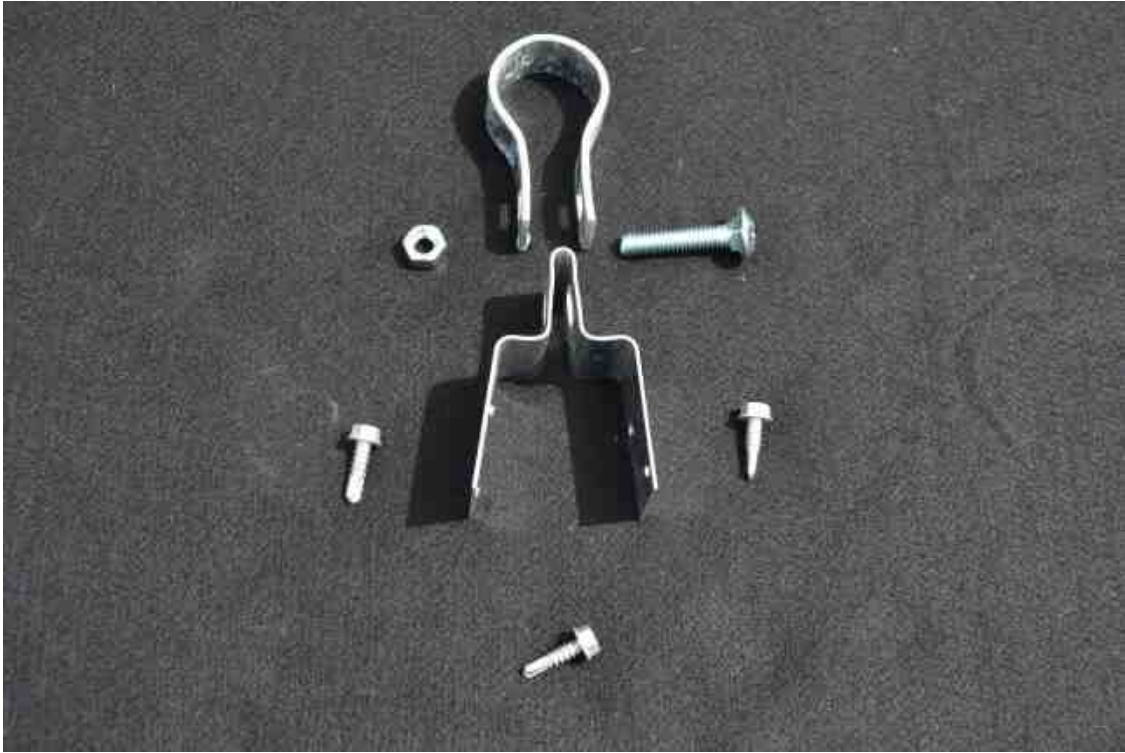



Examples of framing and installation of a roll-up door in the next series of photos



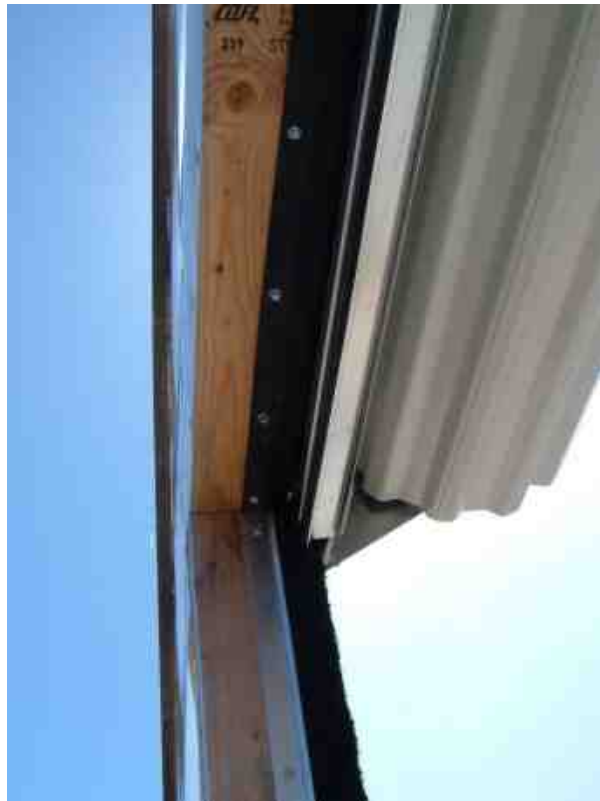







Examples of other framing





LIMITED WARRANTY

Rimol Greenhouse Systems, LLC. (RGS) warrants to only the original purchaser ("Buyer") that the greenhouse frame(s) manufactured by RGS will be free of defects in materials and workmanship for a period of five (5) years. This limited warranty shall not be effective unless the Buyer's greenhouse is installed on level ground and there are no other objects or structures within ten (10) feet of the greenhouse, and the Buyer hereby waives any claims under this warranty in the event these two conditions are not satisfied.

This warranty covers all defects in material and workmanship, EXCEPT:

1. Damage resulting from accident, misuse, abuse, neglect or from other than normal and ordinary use of the frame(s).
2. Damage resulting from failure to use the product in accordance with RGS specifications and instructions.
3. Damage resulting from repair or attempted repair by anyone other than RGS or an authorized repair contractor or facility.
4. Damage resulting from the use or installation of any other equipment or products used in the greenhouse.

This warranty applies only to the products being supplied by RGS and physically attached to the RGS products at the RGS factory. Defects in equipment installed with any RGS product, or defects in the installation of the RGS product, whether or not sold by RGS, are warranted, if at all, by the installers or manufacturers of such equipment, and are not covered by this warranty.

RGS makes no warranties other than those stated above and specifically does not warrant that any of the RGS frames, parts or products are of a merchantable equality or that they can be used for any particular purpose by the buyer.

RGS shall have the right to inspect any parts before taking corrective measures under this warranty.

RGS shall be notified of any warranty claim within 48 hours of damage. Proof of purchase must be furnished with any claim.

LIMITATION OF LIABILITY

In no event will RGS be liable for incidental, consequential, special or indirect damages, lost business profits, regardless of the form of action, whether in contract, tort (including negligence), breach of contract, breach of warranty or otherwise, even if RGS has been advised as to the possibility of same. Buyer's sole and exclusive remedy is repair or replacement, at RGS's option, of any defective parts or workmanship. In the event this exclusive remedy fails of its essential purpose, Buyer's exclusive remedy shall be refund of the defective part.

JURISDICTION

Any disputes arising between RGS and Buyer shall be governed by New Hampshire law without regard to conflicts of law principles. Buyer hereby submits, and waives any objection, to the exclusive personal and subject matter jurisdiction by New Hampshire courts and submits, and waives any objection, to New Hampshire as the proper venue for any disputes.